

## Technical Datasheet



### Solo Innova

Solo Innova is a patented, wood-fired gasification boiler available in two sizes with outputs from 102,500 to 170,700 Btu/hr.



### Benefits at a Glance:

- Add on to your existing fossil-fuel-fired or electric heating system
- Can be used with hot water baseboard, radiant floor, or hot air systems.
- Overall efficiencies of over 80%.
- Clean burn with virtually no smoke or creosote.
- Large easily accessible firebox.
- Smoke-free loading.
- Easy to clean with very little ash.
- The internal boiler is made from 7mm thick plate steel.
- Constructed to design standard EN 303-5 and are designed for pressurized systems.
- Covered by a 20-year limited warranty.

---

# Boiler Information

## Boiler Cut-Away Section

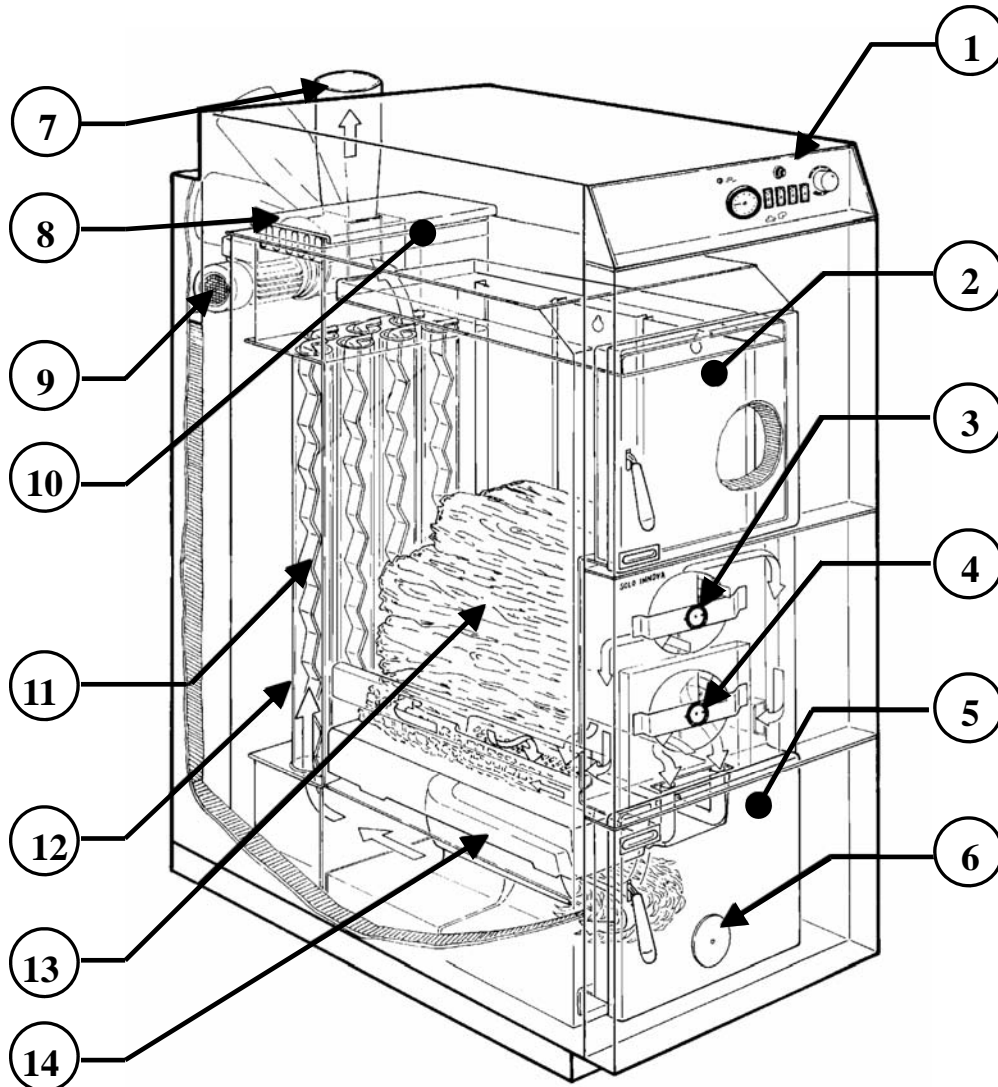

- |                          |                                |
|--------------------------|--------------------------------|
| 1. Control Panel         | 8. Clean-Out Cover             |
| 2. Load Door             | 9. Draft Fan                   |
| 3. Primary Air Control   | 10. Boiler Serial Number Plate |
| 4. Secondary Air Control | 11. Flue Gas Turbulators       |
| 5. Ash Door              | 12. Heat Exchanger Pipes       |
| 6. Sight Glass           | 13. Firebox                    |
| 7. Exhaust Stack         | 14. Gasification Tunnel        |

## Specification Data

Technical Data	Units	30	50
<b>Measurements</b>			
Depth- Boiler -Total	inches	46¾"	46¾"
Width- Boiler -Total	inches	23"	27¼"
Height to Chimney Connection	inches	54"	54"
Smoke Pipe Stub outside diameter	inches	6"	6"
Weight- Empty	lbs	1113	1213
Water Contents	gallons	34	48
Loading Door	inches	14" X 12"	14" X 12"
Combustion chamber Depth	inches	21½"	21½"
Combustion Chamber Volume	gallons	35.66	48.87
Wood Length	inches	20	20
Wood Diameter (Max)-Softwood	inches	4	4
Wood Diameter (Max)-Hardwood	inches	6	6
<b>Operating Data</b>			
Operating Temperature-Water	F°	180-190	180-190
Nominal Output	Btu/hr	102,000	171,000
Flue Gas Temperature at Nominal Output	F°	262	213
Dust in Flue Gas	lbs/MBtu	.053	.06
CO in Flue Gas	lbs/MBtu	.43	.46
NO <sub>x</sub>	lbs/MBtu	.30	.23
Required Draft	inch WC	-.025" to -.05"	-.025" to -.05"
Safety Listings	-	UL 391-1995, CAN/CSA B366.1-91,UL726, ANSI Z21.13-200, CSA 4.9-M2000	UL 391-1995, CAN/CSA B366.1-91,UL726, ANSI Z21.13-200, CSA 4.9-M2000
<b>Electrical Data</b>			
Boiler Power Requirement	-	240V-60Hz/15A	240V-60Hz/15A
Blower	kW	.24	.24
<b>Piping Data</b>			
Boiler Test Pressure	psi	65	65
Boiler Relief Valve Setting	psi	30	30
Supply & Return pipe stub size (male npt)	inch	1¼"	1¼"
Minimum Boiler Loop size	inch	1¼"	1¼"
Fill/ drain valve size	inch	.5	.5
Mixing Valve Opening Setting	F°	140	140
Internal Overheat Aquastat Setting	F°	212	212
<b>Boiler Construction Data</b>			
Pressure retaining steel plate material	-	10025, Type S235JR (equivalent to ASME SA-285, Grade C)	10025, Type S235JR (equivalent to ASME SA-285, Grade C)
Boiler wall thickness at the firebox	mm	7	7
Boiler outside wall thickness	mm	4	4
Boiler stay bolts diameter	mm	8	8
<b>Heat Exchange Tubes</b>			
Number of Tubes	-	7	11
Tube Diameter	inch	2	2
Tube Wall Thickness	mm	4	4

# Specification Data

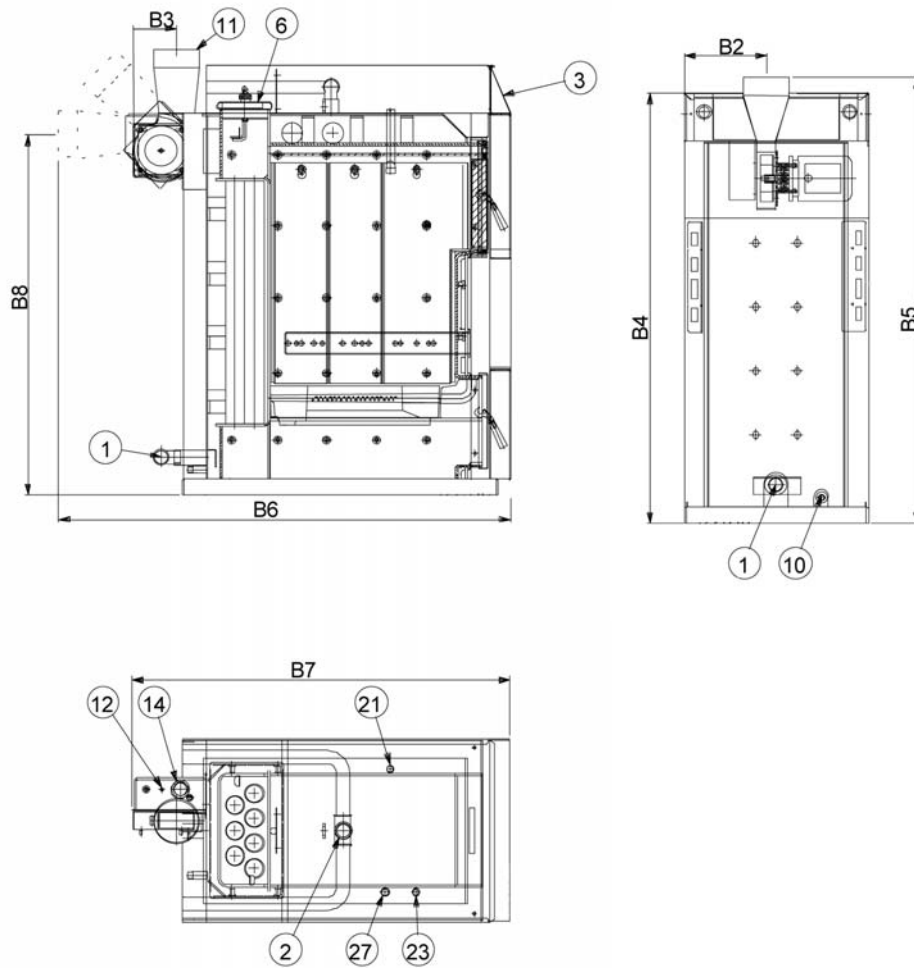

Description	Units	30	50
1. Return Connection	inches	1.250	1.250
2. Supply Connection	inches	1.250	1.250
10 Drain/Fill	inches	½	½
11 Flue Pipe, External Diameter	inches	6	6
23 Sensor Well-Control Panel	inches	½	½
27 Sensor Well- Overheat Aquastat	inches	½	½
B2 Measurement	inches	10.43	14.17
B3 Measurement	inches	5.71	5.71
B4 Measurement	inches	54.13	54.13
B5 Measurement	inches	56.10	56.10
B6 Measurement	inches	56.69	56.69
B7 Measurement	inches	46.77	46.77
B8 Measurement	inches	45.28	45.28

Boiler Clearances

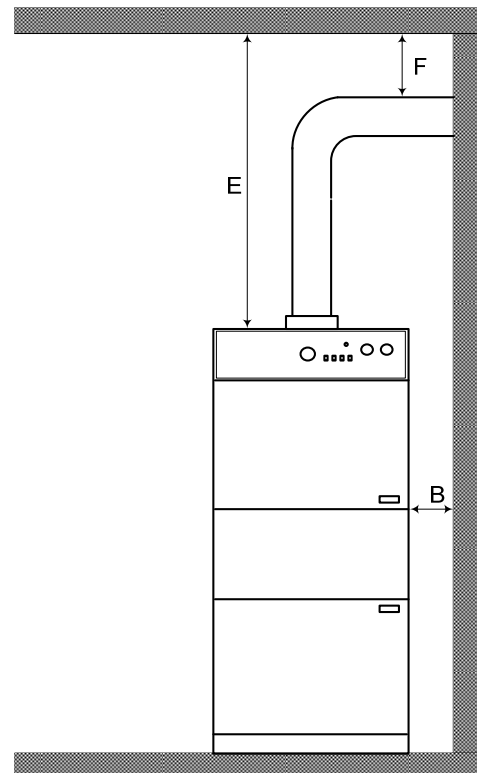
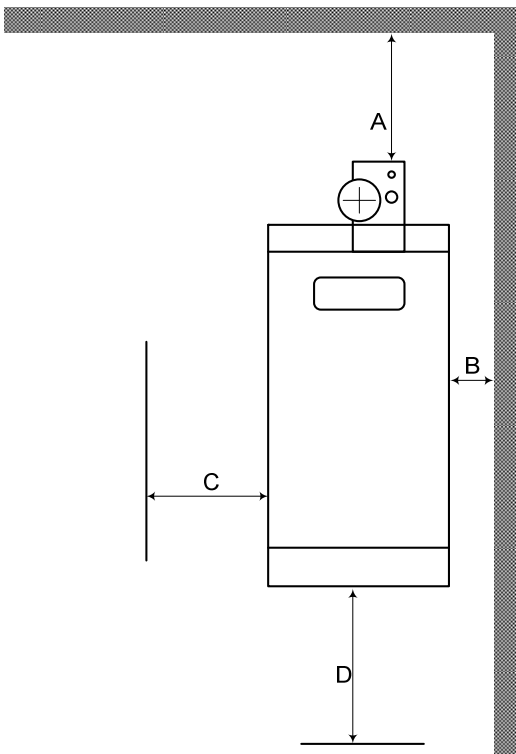

Clearances to Combustibles		
Measurement	Minimum Distance	Notes
A-Backwall to Appliance	21"	Minimum Distance to allow clearance for blower maintenance.
B-Sidewall to Appliance	12"	Minimum Distance
C-Sidewall to Appliance	21"	Minimum Distance on left side to allow clearance for Cleaning and Maintenance Tasks.
D-Front of Appliance	36"	Required Distance for Cleaning the Boiler.
E-Ceiling to Appliance	24"	Required Distance for Cleaning the Boiler.
F-Combustibles to Pipe	18"	Minimum Distance

## System Design Considerations

### Sizing

It is critical to size the boiler properly. A proper, up to date heat load calculation is advised. An accurate history of building fuel usage over several years can help to calculate the proper size boiler. Be wary of using simple techniques based only on square footage. The heat load of a home can vary widely depending on age and type of heating system and location of the home. Boiler sizing is the responsibility of the installer. Tarm Biomass bears no responsibility for boiler sizing, but can provide sizing input.

### Chimney

The chimney is the most critical factors in the successful operation of any solid fuel heater, including the Solo Plus boiler. A good chimney will provide a continuous and dependable draft to pull the exhaust gasses out of the building. The boiler must be connected to a tile-lined masonry chimney or to a Factory-Built Type UL 103 HT (ULC S629 in Canada) approved chimney. The chimney must be in good condition. If the boiler is connected to a dirty or inadequate chimney, it can present a serious fire hazard. All chimney connections must conform to NFPA standard #211. No other appliance should be connected to this flue unless allowed by the local code authority. Consult your local inspector for chimney requirements and install the boiler in accordance with all applicable codes.

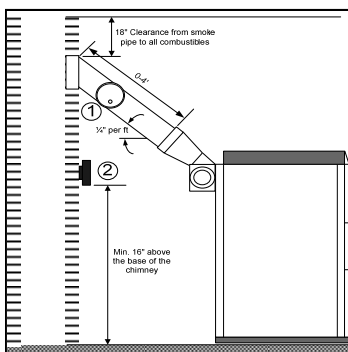

### Outside Combustion Air

Provision for outside combustion air may be necessary to ensure that fuel-burning appliances do not discharge products of combustion into the house. Guidelines to determine the need for additional combustion air may not be adequate for every situation. If in doubt, it is advisable to provide additional air.

The Solo Innova boiler is not suitable for direct connection to outside air. Outside air should be ducted to no closer than 12" from the boiler.

The boiler must not be installed in an area or room where there are flammable liquids or combustibles. Examples include, refrigerants, paint, thinner, bleach, etc.

### Boiler Location

The boiler is not suitable for outdoor installation. It must be located in a weather-tight, protected space. The boiler must be placed on a level, non-combustible floor, such as a concrete slab on earth. If you have the boiler 8" (203mm) above the floor it makes it easier to load and clean the boiler. If the boiler is placed near inhabited rooms, so that the flue gas can easily penetrate into these rooms, a carbon monoxide alarm must be installed that can give a warning regarding possible escapes of carbon monoxide into the inhabited rooms.

### Electrical

For the Solo Innova boiler a 240 VAC, 60 hertz, 4 wire power supply is required. This electrical connection should be from a dedicated 15 amp, circuit breaker. A master service switch for the boiler, mounted on the wall in the proximity of the boiler, is recommended. Locally enforced electrical codes must be followed.

### Water Quality

If water quality is poor, water treatment should be considered. Boiler system pH should be 8.0-8.6.

An anti-freeze can be utilized in areas where freezing could occur. Automotive or silicate-based anti-freeze cannot be used. Use only anti-freeze approved for heating systems. Using anti-freeze can cause a loss in heating efficiency and some heating components within the system could be negatively impacted.

### System Plumbing

For the heating system piping, it is possible to use either copper or iron piping materials. The supply and return pipe should be insulated to avoid heat loss.

In systems where plastic tubing is used, it must have an oxygen diffuser barrier. If non-oxygen barrier tubing is used, the boiler must be separated from the tubing by a heat exchanger.

A thermostatic mixing valve, set to open at 140 °F (60 °C), is required to temper return water to prevent cold return water from reaching the boiler. This valve helps prevent boiler corrosion.

### Boiler Accessories

- Ash Pan
- Barometric Damper
- Termovar Mixing Valve
- Termovar Loading Unit
- Flue Thermometer
- Aquastats
- Thermal Storage Systems
- Indirect Water Heaters