



froling 

FHG Turbo 3000

Wood-fired
Gasification
Boiler

FHG Turbo 3000



Wood-fired Gasification Add-on Boiler



Independence and Self-reliance

Fröling Turbo 3000 boilers provide a convenient, safe and environmentally responsible way to heat your home and hot water with wood. Turbo 3000 homeowners are assured of unusually high heating efficiency, low heating costs, and use of an abundant, locally available, renewable fuel. The wood gasification combustion technology found in the Turbo 3000 is the most efficient way to burn cordwood. As a result, Turbo 3000 boilers use substantially less wood than conventional boilers and outdoor water stoves. Additionally, this high-efficiency burn technology produces little or no creosote, virtually eliminating the risk of chimney fires and greatly reducing greenhouse gas emissions.

Sizing Your Boiler

As with any heating system, choosing an appropriately sized heat source is necessary to optimize efficiency, ease of operation and home comfort. Be wary of using simple techniques based only on square footage.

About BioHeatUSA

BioHeatUSA™, formerly Tarm USA, is a third-generation, family-owned business that has pioneered the sales and service of European residential central heating equipment in North America for over 30 years. BioHeatUSA's primary objective is to offer innovative home heating solutions, along with a significant commitment to consumer education and environmental awareness. Exclusive partnerships with ISO 9001 certified manufacturers allows BioHeatUSA to offer products with operational reliability, unique firing efficiency, and to promote the clean burning of carbon-cycle biomass that is critical to the lowering of net greenhouse gas emissions.

About Fröling

Founded in 1961, Fröling is a family-owned company located in Grieskirchen, Austria. A pioneer in wood-fired heating systems, Fröling has devoted decades of intensive R&D to the study of maximum energy efficiency.

The heat load of a home can vary widely depending on age and type of construction, type of heating system and location of the home. If you have questions about which boiler is most appropriate for your needs, please contact your local BioHeatUSA dealer or contact us directly at our toll free number and we would be happy to discuss your application with you.

Innovation

The Fröling Turbo 3000 series has several features that are unique in this market and make it what we believe to be the finest wood boiler available in North America.

- Foremost of these is the Lambdatronic control. The Lambdatronic continuously monitors and adjusts combustion and exhaust parameters through the entire burn cycle giving the Turbo 3000 the cleanest burn possible and allowing the Turbo 3000 to achieve an unmatched efficiency of over 90%.
- The Efficiency Optimization System (EOS) allows you to maintain maximum heat transfer efficiency of the heat exchange tubes by means of an external handle. By moving this handle, the turbulators are actuated in such a way that any residual fly-ash that may have built up on the boiler tube surfaces is scrubbed off and falls into the bottom of the boiler. The actuation handle may be located on either side of the boiler.

Fröling 3000 Applications

- add on to your existing fossil-fuel-fired or electric heating system
- hot water baseboard
- radiant floors
- hot air

■ As with any solid fuel burning appliance, ash must be removed periodically. The bulk of the ash builds up just inside the bottom door of the boiler and can easily be removed. Some fly ash, however, will also build up at the back of the boiler beneath the vertical heat exchange tubes and in other boilers can be awkward to remove. In order to address this issue, the Turbo 3000 has a unique second ash removal door located near the back of the boiler. This door may be mounted on either side of the boiler and makes complete ash removal a snap.

■ The Ignition Port is a small door on the front of the boiler between the upper loading door and the lower ash removal door. When lighting a new fire simply place kindling and firewood into the firebox. Next, place crumpled newspaper into the Ignition Port, turn on the fan, light the paper, wait for a small fire to be established, and close the door. Your fire will take off and begin gasifying in minutes. Simple.

■ When adding wood to an established fire in most wood boilers, smoke can roll out of the open loading door into your home. The Turbo 3000, on the other hand, has a smoke extraction passage along the top of the firebox. Any smoke that tries to roll out of the loading door is pulled into this passage and into the chimney preventing any smoke from entering your home.

Optimization and Heat Storage

Firewood burns most efficiently and cleanly when it is burned hot and fast. A down-draft gasification boiler like the Turbo 3000 facilitates just this kind of burn. Your home, however, does not use heat in this same way; it calls for heat only as needed. In order to meet both of these demands, we recommend combining any wood boiler with a water storage tank of 500-1000 gallons. By using this type of thermal storage your Turbo 3000 boiler will always burn hot and fast—even if your home is not calling for heat.

Features

- 91% overall efficiency¹
- clean burn with virtually no smoke or creosote
- large, easily accessible firebox
- easy to clean; manual turbulators for heat exchanger tubes

¹ as per Austrian efficiency test protocol

Quality

The Turbo 3000 boiler is made of fully welded 6mm thick steel with additional 3mm steel firebox aprons. BioHeatUSA boilers are constructed to European boiler design standard EN 303-5 and are to be used in pressurized systems. The Turbo 3000 is UL and ULC approved.



A heat storage unit is an excellent addition to any home heating solution.

Instead of smoking and smoldering in idle mode when your home is up to temperature, a storage tank will allow the Turbo 3000 to continue to burn at maximum efficiency. The excess heat generated will simply be stored in the water tank for use later. A certain amount of idling is acceptable, and if you intend to burn wood only during the coldest part of the year, no storage tank is necessary. However, without a storage tank, once the warm days of early spring arrive, it will be time to shut down your wood boiler for the summer. By incorporating thermal storage you will maximize the efficiency of your wood boiler and be able to continue to use your boiler throughout the spring and fall for space heating—and even right through the summer to produce your domestic hot water if you choose. Thermal storage can be easily added to a system at a later date.

Control

A menu-driven user interface is used to obtain information about boiler start up, exhaust gas and boiler temps, residual oxygen content, outdoor temperature and more. The Lambdatronic control system with a Lambdatronic micro-processor means code is written to ensure:

- Regulation of performance through precise control of the variable speed draft fan.
- Continual adjustment of combustion air to automatically match burn characteristics to the species, moisture content and shape of wood used.
- Continuous optimization of combustion through exhaust gas analysis and adjustment of exhaust gas temperature.

How it Works

Kindling, tinder and paper are loaded into the Turbo 3000 followed by standard cord wood. The fire is then lit via the Ignition Port. This small access door is unique in the industry and makes lighting a fire very quick and easy. The wood gasification combustion process begins when the draft induction fan turns on and pulls fresh air into the boiler. This air is pulled into the bottom of the firebox and down through the live charcoal bed. The primary combustion that takes place in the firebox produces a hot mixture of unburned gases that are pulled down into the patented Vortex secondary combustion chamber. Simultaneously, additional pre-heated air is injected into this stream of hot gases resulting in a very hot 1800°F to 2000°F secondary burn. Only at these temperatures can a high efficiency, clean burn be achieved.



Image used for informational purposes only.
Actual appearance may vary.

Standard Equipment

- Lambdatronic combustion control
- Efficiency optimization system
- Fire ignition port
- Smoke roll-out extraction
- Ash clean-out port

Optional Equipment

- Heat storage system
- Termovar mixing valve
- Contact BioHeat USA for a full list of accessories

Warranty

Each Turbo 3000 boiler is covered by a 20-year limited warranty. A copy is available for your inspection, and is provided with each boiler.

Disclaimer

BioHeatUSA is not responsible for factory alterations to measurements. For final specifications, please see the Fröling Turbo 3000 Owner's Manual.

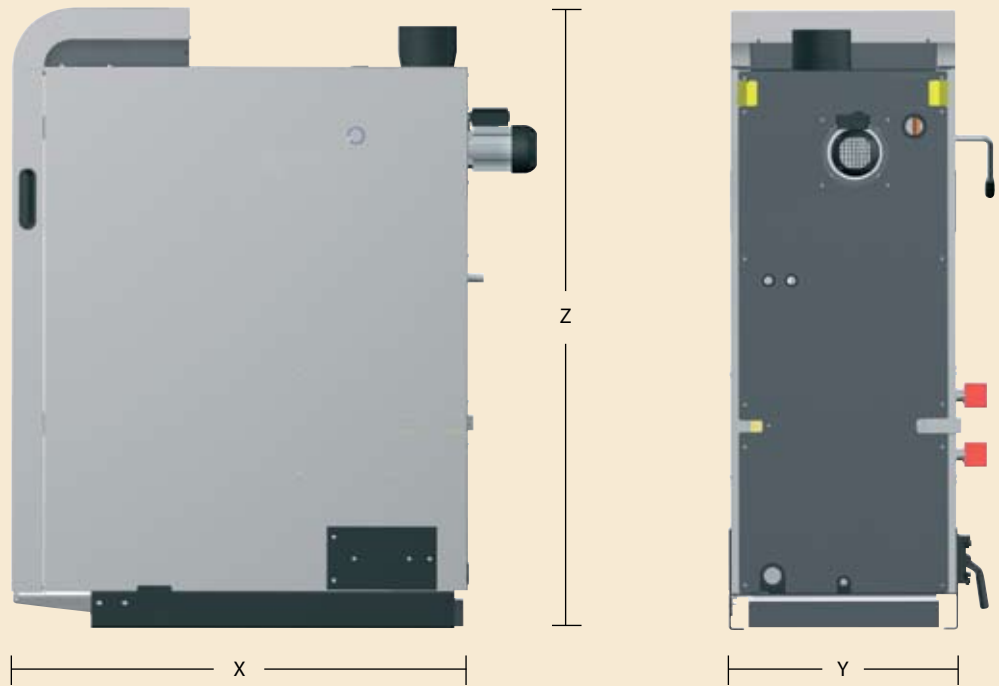

State-of-the-art robotics technology within Fröling's manufacturing plant.

Technical Data

		20	30	40	50
Maximum heat output	BTU/hr	70,000	102,500	136,560	170,700
Loading door	inches	13 X 14½	13 X 14½	13 X 14½	13 X 14½
Firebox volume	cubic feet	5	5	7.4	7.4
Max. wood length	inches	21½	21½	21½	21½
Unit length X	inches	45¼	45½	49½	49½
Unit width Y	inches	22¾	22¾	22¾	22¾
Unit height Z	inches	61¾	61¾	65¾	65¾
Unit weight	pounds	1150	1160	1340	1360
Flue collar size	inches	6	6	6	6
Height of flue collar	inches	60¼	60¼	60¼	60¼

Dimensions are subject to technical alterations.

