

TERMOVAR LOADING VALVE

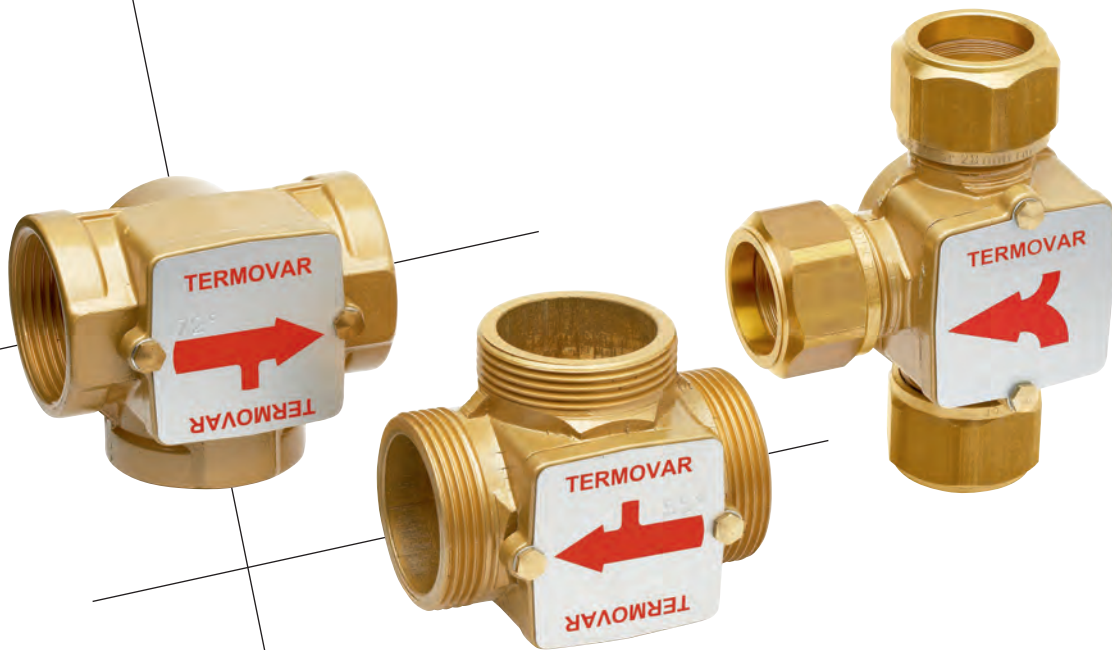

TECHNICAL DATA

Opening temperature	45°C, 55°C, 61°C, 72°C or 80°C fixed temperature
Max. operating temperature	110°C
Max. operating pressure	1.0 MPa (10 bar)
Valve body of brass	TV 15 – TV 40
Valve body of cast iron	TV 40 – TV 50

TERMOVAR LOADING VALVE is an automatic thermally operated loading valve for solid-fuel boiler/storage tank installations, where heating and domestic hot water are taken from the tank.

TERMOVAR ensures a minimum return-water temperature in the heating boiler, which increases the efficiency, prevents tarring and considerably prolongs the lifetime of the solid-fuel boiler.

TERMOVAR eliminates the risk of destructive thermal shock to both steel and cast iron boilers. TERMOVAR thermally operated loading valve renders a more effective burning and is therefore a necessary part of a solid fuel installation with a storage tank.

TERMOVAR LOADING VALVES may be selected with 45°C, 55°C, 61°C, 72°C or 80°C fixed opening temperatures.

The valves can be delivered factory mounted in any position and with other temperatures on request.

LK ACASO AB
Box 634
SE-521 21 Falköping
Tel: +46 515 107 50
Fax: +46 515 590 30

E-mail: info@lkacaso.se
Internet: www.lkacaso.se



LK Acaso

TERMOVAR LOADING VALVE

ORDERING DATA FOR TERMOVAR BRASS VALVES

Order No.	Type	Kvs	A mm	B mm	C mm	D mm	E mm	Weight kg
4115	TERMOVAR 15 45°C Rp 1/2"	4	21,3	80	21	31	65	0,7
4120	TERMOVAR 20 45°C Rp 3/4"	6	26,9	80	21	31	65	0,7
4125	TERMOVAR 25 45°C Rp 1"	9	33,7	82	21	32	66	0,7
4132	TERMOVAR 32 45°C Rp 1 1/4"	12	42,4	84	25	32	67	0,8
4120A	TERMOVAR 20A 45°C G 1/2"	4	21,3	80	21	31	65	0,7
4125A	TERMOVAR 25A 45°C G 3/4"	6	26,9	80	21	31	65	0,7
4132A	TERMOVAR 32A 45°C G 1"	9	33,7	82	21	32	66	0,7
4140A	TERMOVAR 40A 45°C G 1 1/4"	12	42,4	84	25	32	67	0,8
4115K	TERMOVAR 15K 45°C 15 mm	4	15,0	114	21	31	81	0,8
4122K	TERMOVAR 22K 45°C 22 mm	6	22,0	114	21	31	81	0,8
4128K	TERMOVAR 28K 45°C 28 mm	9	28,0	119	21	32	85	1,0
4215	TERMOVAR 15 55°C Rp 1/2"	4	21,3	80	21	31	65	0,7
4220	TERMOVAR 20 55°C Rp 3/4"	6	26,9	80	21	31	65	0,7
4225	TERMOVAR 25 55°C Rp 1"	9	33,7	82	21	32	66	0,7
4232	TERMOVAR 32 55°C Rp 1 1/4"	12	42,4	84	25	32	67	0,8
4220A	TERMOVAR 20A 55°C G 1/2"	4	21,3	80	21	31	65	0,7
4225A	TERMOVAR 25A 55°C G 3/4"	6	26,9	80	21	31	65	0,7
4232A	TERMOVAR 32A 55°C G 1"	9	33,7	82	21	32	66	0,7
4240A	TERMOVAR 40A 55°C G 1 1/4"	12	42,4	84	25	32	67	0,8
4215K	TERMOVAR 15K 55°C 15 mm	4	15,0	114	21	31	81	0,8
4222K	TERMOVAR 22K 55°C 22 mm	6	22,0	114	21	31	81	0,8
4228K	TERMOVAR 28K 55°C 28 mm	9	28,0	119	21	32	85	1,0
4315	TERMOVAR 15 61°C Rp 1/2"	4	21,3	80	21	31	65	0,7
4320	TERMOVAR 20 61°C Rp 3/4"	6	26,9	80	21	31	65	0,7
4325	TERMOVAR 25 61°C Rp 1"	9	33,7	82	21	32	66	0,7
4332	TERMOVAR 32 61°C Rp 1 1/4"	12	42,4	84	25	32	67	0,8
4320A	TERMOVAR 20A 61°C G 1/2"	4	21,3	80	21	31	65	0,7
4325A	TERMOVAR 25A 61°C G 3/4"	6	26,9	80	21	31	65	0,7
4332A	TERMOVAR 32A 61°C G 1"	9	33,7	82	21	32	66	0,7
4340A	TERMOVAR 40A 61°C G 1 1/4"	12	42,4	84	25	32	67	0,8
4315K	TERMOVAR 15K 61°C 15 mm	4	15,0	114	21	31	81	0,8
4322K	TERMOVAR 22K 61°C 22 mm	6	22,0	114	21	31	81	0,8
4328K	TERMOVAR 28K 61°C 28 mm	9	28,0	119	21	32	85	1,0
4415	TERMOVAR 15 72°C Rp 1/2"	4	21,3	80	21	31	65	0,7
4420	TERMOVAR 20 72°C Rp 3/4"	6	26,9	80	21	31	65	0,7
4425	TERMOVAR 25 72°C Rp 1"	9	33,7	82	21	32	66	0,7
4432	TERMOVAR 32 72°C Rp 1 1/4"	12	42,4	84	25	32	67	0,8
4420A	TERMOVAR 20A 72°C G 1/2"	4	21,3	80	21	31	65	0,7
4425A	TERMOVAR 25A 72°C G 3/4"	6	26,9	80	21	31	65	0,7
4432A	TERMOVAR 32A 72°C G 1"	9	33,7	82	21	32	66	0,7
4440A	TERMOVAR 40A 72°C G 1 1/4"	12	42,4	84	25	32	67	0,8
4415K	TERMOVAR 15K 72°C 15 mm	4	15,0	114	21	31	81	0,8
4422K	TERMOVAR 22K 72°C 22 mm	6	22,0	114	21	31	81	0,8
4428K	TERMOVAR 28K 72°C 28 mm	9	28,0	119	21	32	85	1,0
4515	TERMOVAR 15 80°C Rp 1/2"	4	21,3	80	21	31	65	0,7
4520	TERMOVAR 20 80°C Rp 3/4"	6	26,9	80	21	31	65	0,7
4525	TERMOVAR 25 80°C Rp 1"	9	33,7	82	21	32	66	0,7
4532	TERMOVAR 32 80°C Rp 1 1/4"	12	42,4	84	25	32	67	0,8
4520A	TERMOVAR 20A 80°C G 1/2"	4	21,3	80	21	31	65	0,7
4525A	TERMOVAR 25A 80°C G 3/4"	6	26,9	80	21	31	65	0,7
4532A	TERMOVAR 32A 80°C G 1"	9	33,7	82	21	32	66	0,7
4540A	TERMOVAR 40A 80°C G 1 1/4"	12	42,4	84	25	32	67	0,8
4515K	TERMOVAR 15K 80°C 15 mm	4	15,0	114	21	31	81	0,8
4522K	TERMOVAR 22K 80°C 22 mm	6	22,0	114	21	31	81	0,8
4528K	TERMOVAR 28K 80°C 28 mm	9	28,0	119	21	32	85	1,0

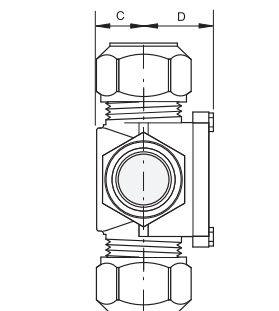
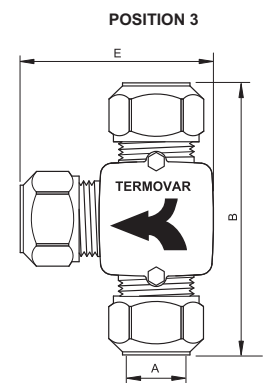
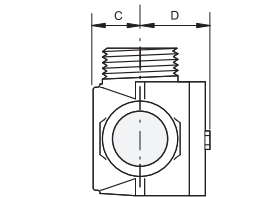
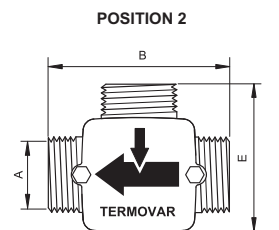
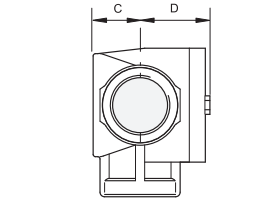
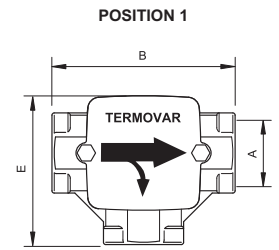

TERMOVAR can be delivered factory mounted in any position and with other temperatures on request
Available with NPT-threads

TERMOVAR LOADING VALVE

ORDERING DATA FOR TERMOVAR CAST IRON VALVES

Order No.	Type	Kvs	A mm	B mm	C mm	D mm	E mm	Weight kg
4140	TERMOVAR 40 45°C Rp 1 1/2"	17	48,3	127	40	48	100	2,8
4150	TERMOVAR 50 45°C Rp 2"	21	60,3	135	48	65	105	4,2
4240	TERMOVAR 40 55°C Rp 1 1/2"	17	48,3	127	40	48	100	2,8
4250	TERMOVAR 50 55°C Rp 2"	21	60,3	135	48	65	105	4,2
4340	TERMOVAR 40 61°C Rp 1 1/2"	17	48,3	127	40	48	100	2,8
4350	TERMOVAR 50 61°C Rp 2"	21	60,3	135	48	65	105	4,2
4440	TERMOVAR 40 72°C Rp 1 1/2"	17	48,3	127	40	48	100	2,8
4450	TERMOVAR 50 72°C Rp 2"	21	60,3	135	48	65	105	4,2
4540	TERMOVAR 40 80°C Rp 1 1/2"	17	48,3	127	40	48	100	2,8
4550	TERMOVAR 50 80°C Rp 2"	21	60,3	135	48	65	105	4,2

TERMOVAR can be delivered factory mounted in any position and with other temperatures on request

POSITION 1

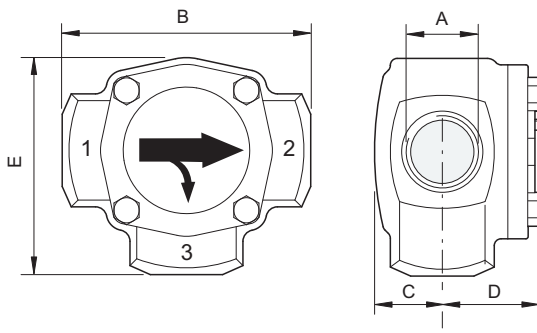

POSITION 2

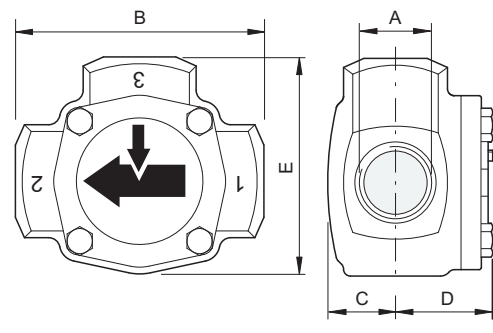

Capacity diagramm

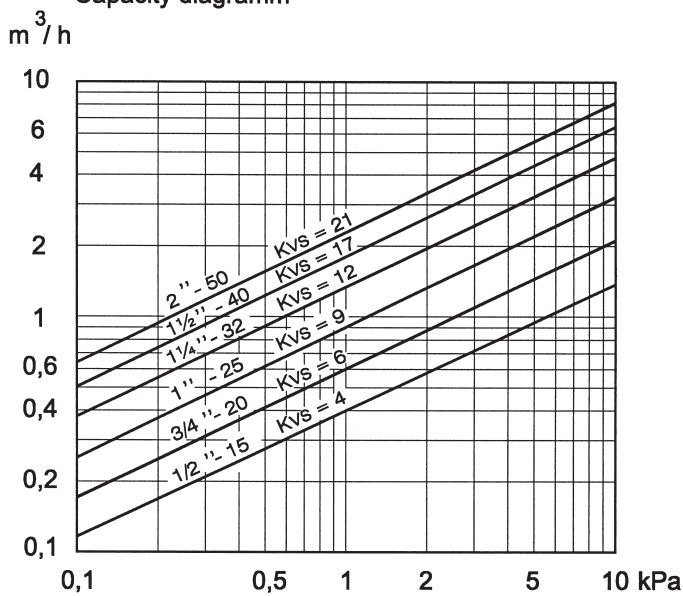

POSITION 3

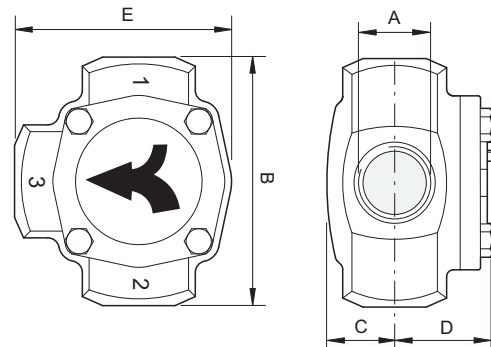

INSTALLATION

INSTALLATION POSITION 1:

TERMOVAR 45°C - 55°C - 61°C - 72°C or 80°C

INSTALLATION:

TERMOVAR installed in the supply water pipe.

FUNCTION:

When the solid-fuel boiler has reached the selected temperature the thermal valve opens. Supply water from the boiler is loaded to the storage tank. Return water from the storage tank is mixed with supply water before flowing back to the boiler. The loading continues as long as the boiler is being fired. A balancing valve is to be installed between boiler and loading valve.

TERMOBAC:

When the loading of the storage tank is completed the circulation pump will shut off. The TERMOBAC will now prevent self-circulation from storage tank back to boiler. In case of power or pump failure the TERMOBAC will open automatically for self-circulation.

LOADING PUMP:

The loading pump should be controlled by a thermostat which measures boiler temperature. The pump will start when the boiler is at operating temperature and stop when the boiler drops below this temperature.

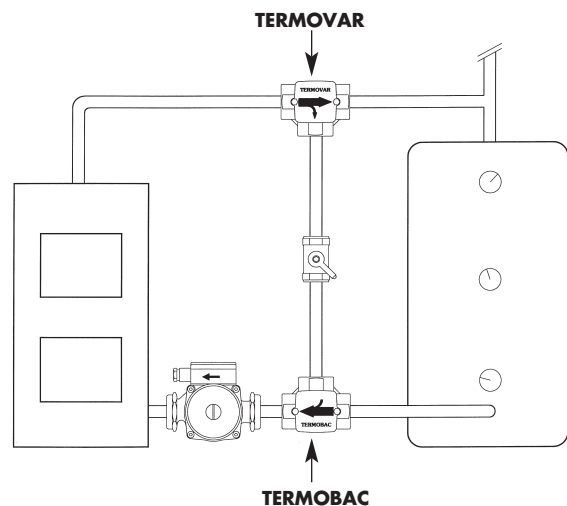

INSTALLATION POSITION 2:

TERMOVAR 45°C - 55°C - 61°C - 72°C or 80°C

INSTALLATION:

TERMOVAR installed in the return water pipe.

FUNCTION:

When the solid-fuel boiler has reached the selected temperature the thermal valve opens. Supply water from the boiler is loaded to the storage tank. Return water from the storage tank is mixed with supply water before flowing back to the boiler. The loading continues as long as the boiler is being fired. A balancing valve is to be installed between boiler and loading valve.

LOADING PUMP:

The loading pump should be controlled by a thermostat which measures boiler temperature. The pump will start when the boiler is at operating temperature and stop when the boiler drops below this temperature.

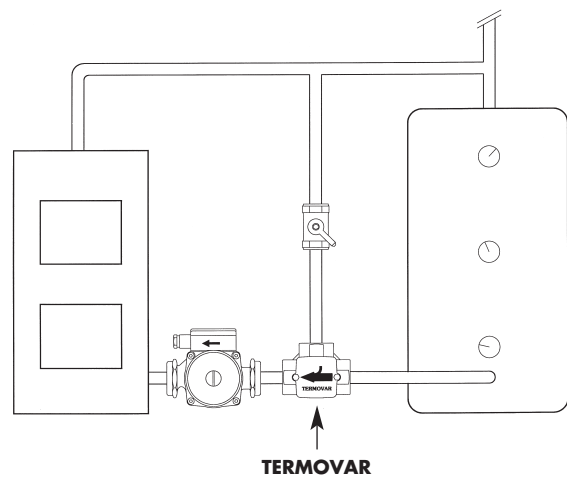

INSTALLATION POSITION 3:

TERMOVAR 45°C - 55°C - 61°C - 72°C or 80°C

INSTALLATION:

TERMOVAR installed between supply water pipe and return water pipe.

FUNCTION:

When the solid-fuel boiler has reached the selected temperature the thermal valve opens. Supply water from the boiler is loaded to the storage tank. Return water from the storage tank is mixed with supply water before flowing back to the boiler. The loading continues as long as the boiler is being fired. A balancing valve is to be installed between boiler and loading valve.

TERMOBAC:

When the loading of the storage tank is completed the circulation pump will shut off. The TERMOBAC will now prevent self-circulation from storage tank back to boiler. In case of power or pump failure the TERMOBAC will open automatically for self-circulation.

LOADING PUMP:

The loading pump should be controlled by a thermostat that measures flue-gas temperature. The pump will start when the boiler is fired up and stop when it has ceased to fire.

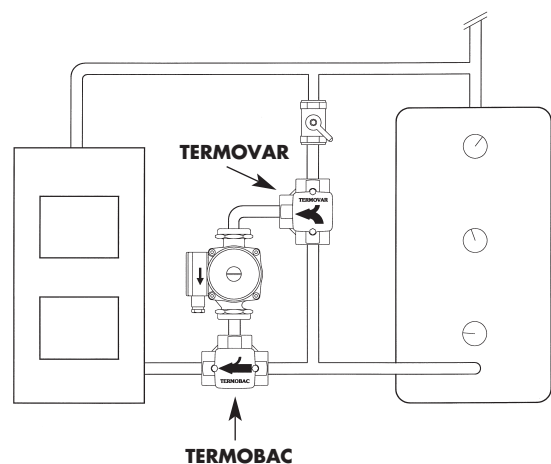

LK Acaso